

STATO DI FATTO

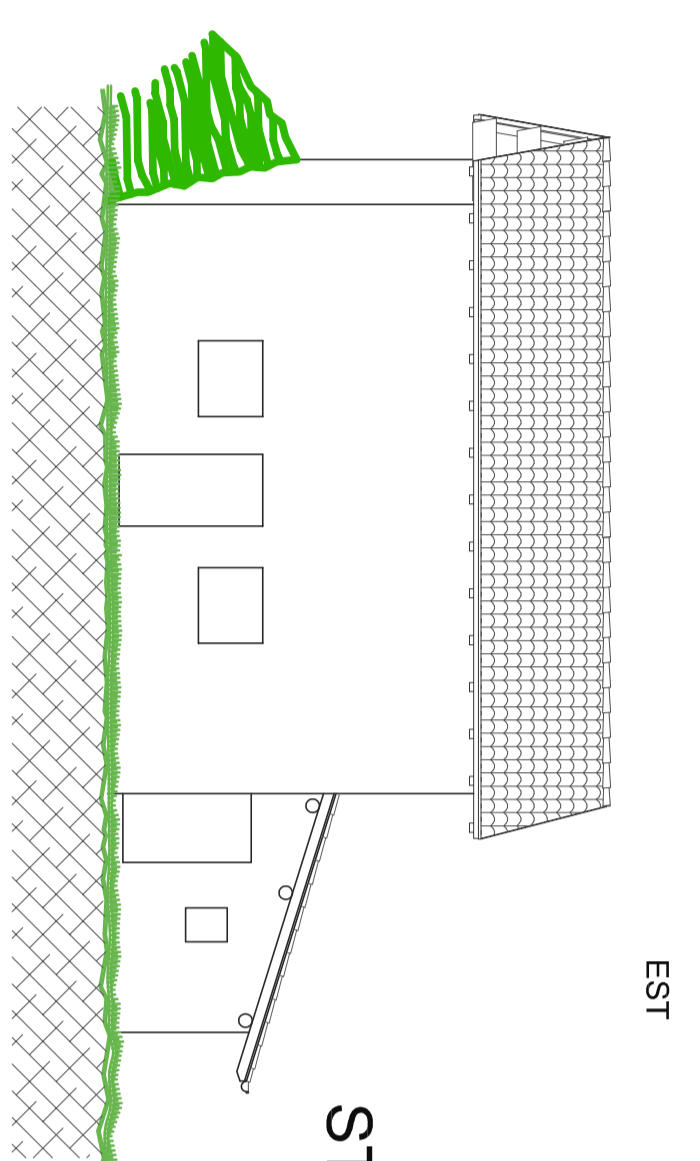

STATO DI FATTO

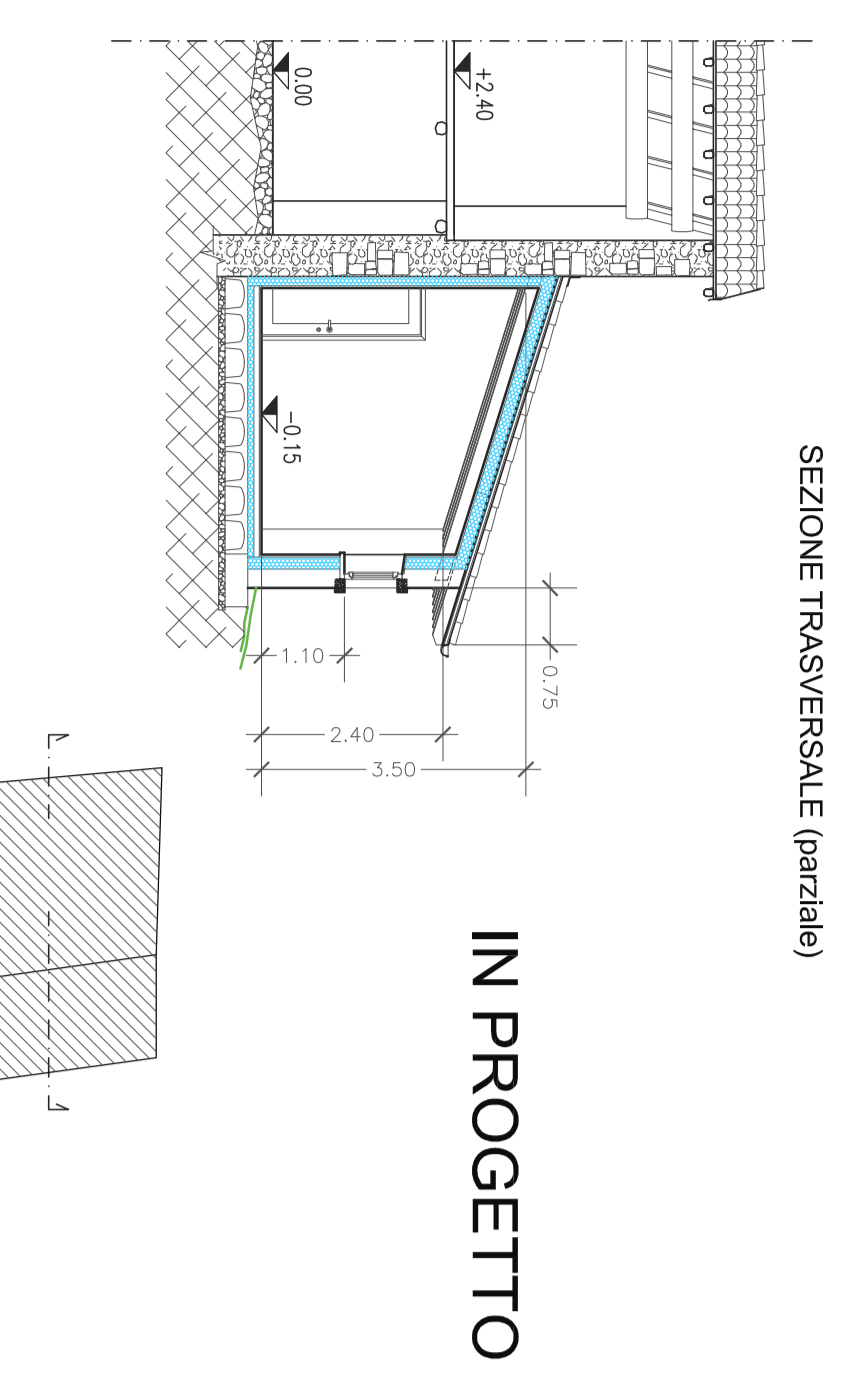
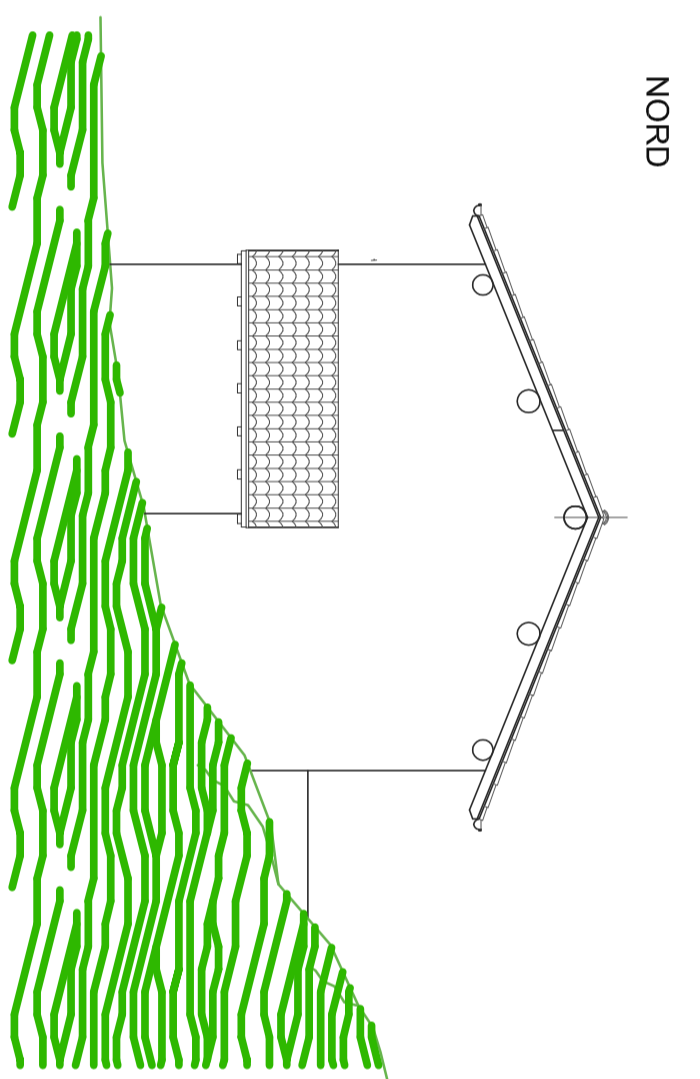

IN PROGETTO

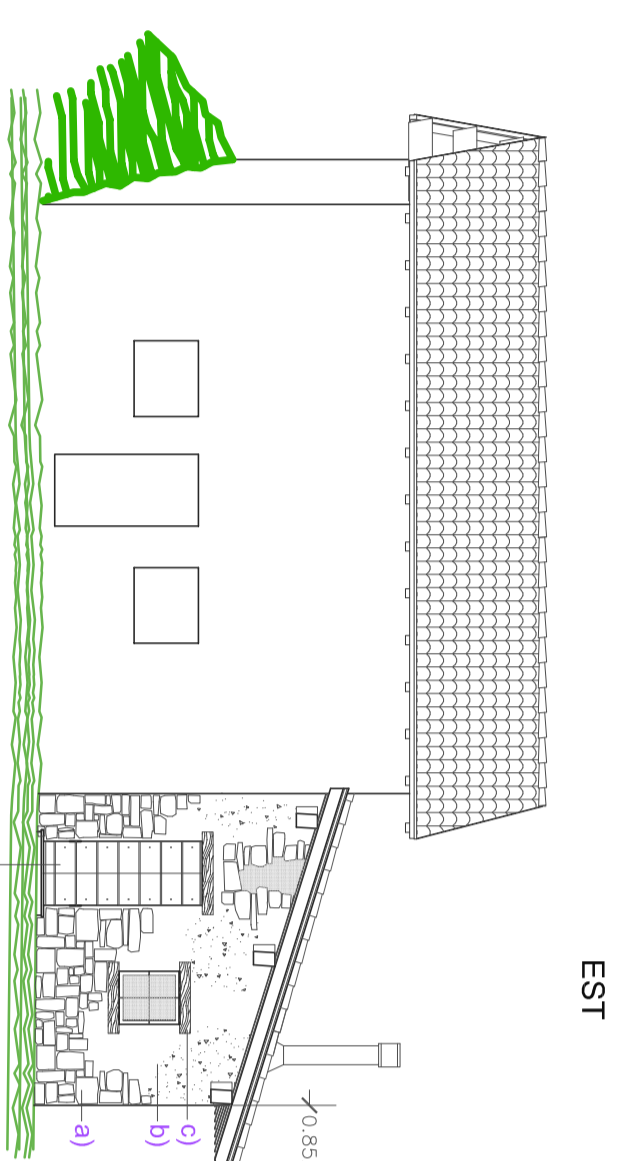

IN PROGETTO

(a) mantoio con tegole di origine esistente
 (b) mantoio di Sarda in no, nuovo progetto
 (c) mantoio di Sarda in no, nuovo progetto
 (d) mantoio di Sarda in no, nuovo progetto
 (e) mantoio di Sarda in no, nuovo progetto
 (f) mantoio di Sarda in no, nuovo progetto

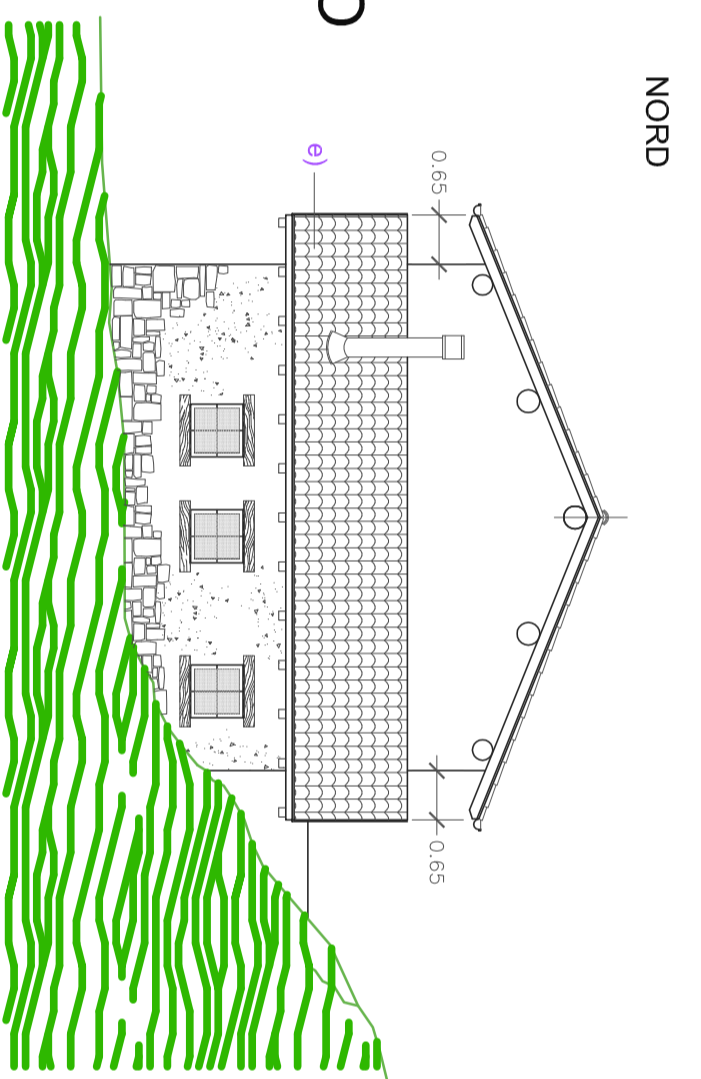

SEZIONE TRASVERSALE (parziale)

EST

NORD

SEZIONE TRASVERSALE (parziale)

EST

NORD

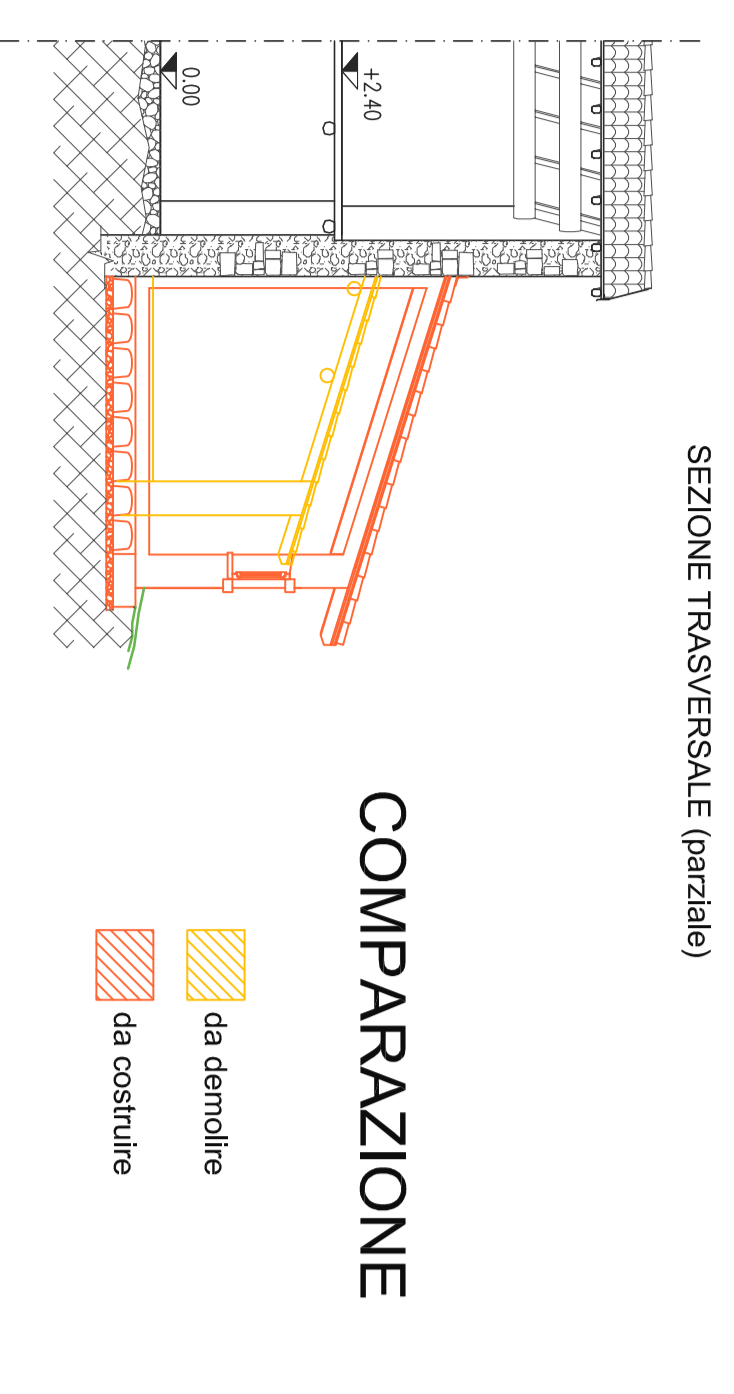

COMPARAZIONE

da demolire
 da costruire

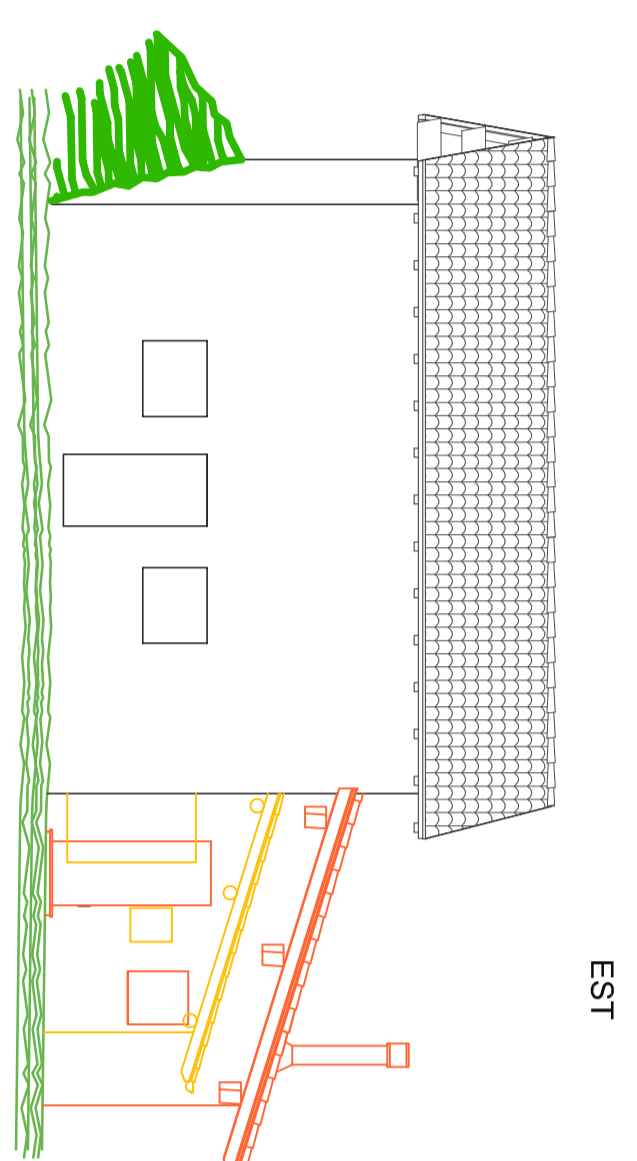

COMPARAZIONE

da demolire
 da costruire

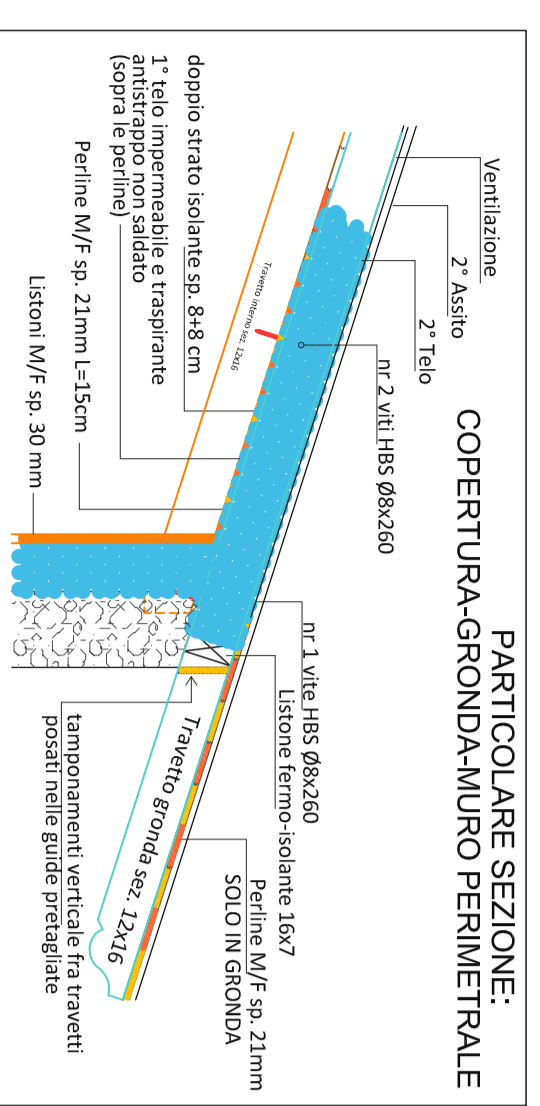

PARTICOLARE SEZIONE: COPERTURA-GRONDA-MURO PERIMETRALE

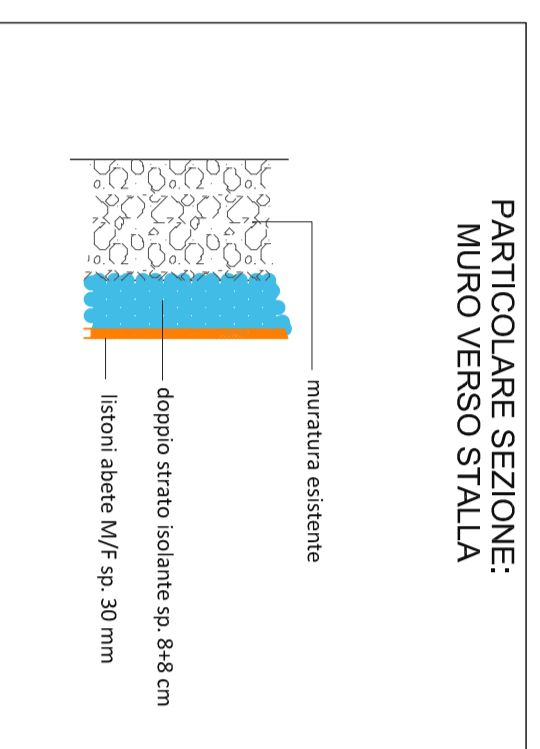

PARTICOLARE SEZIONE: MURO VERSO STALLA

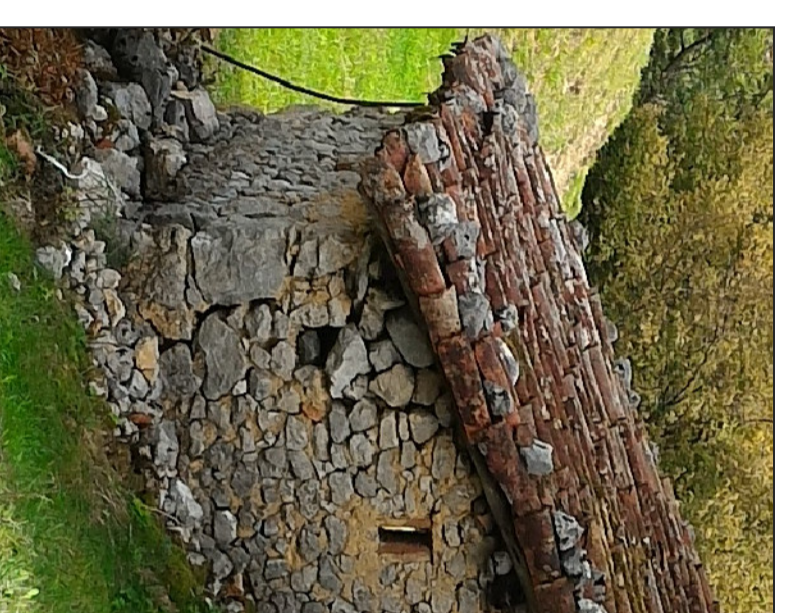

PARTICOLARE DELLA MURATURA PERICOLANTE



RIPRESA FOTOGRAFICA DA NORD-EST



RIPRESA FOTOGRAFICA DA NORD-OVEST

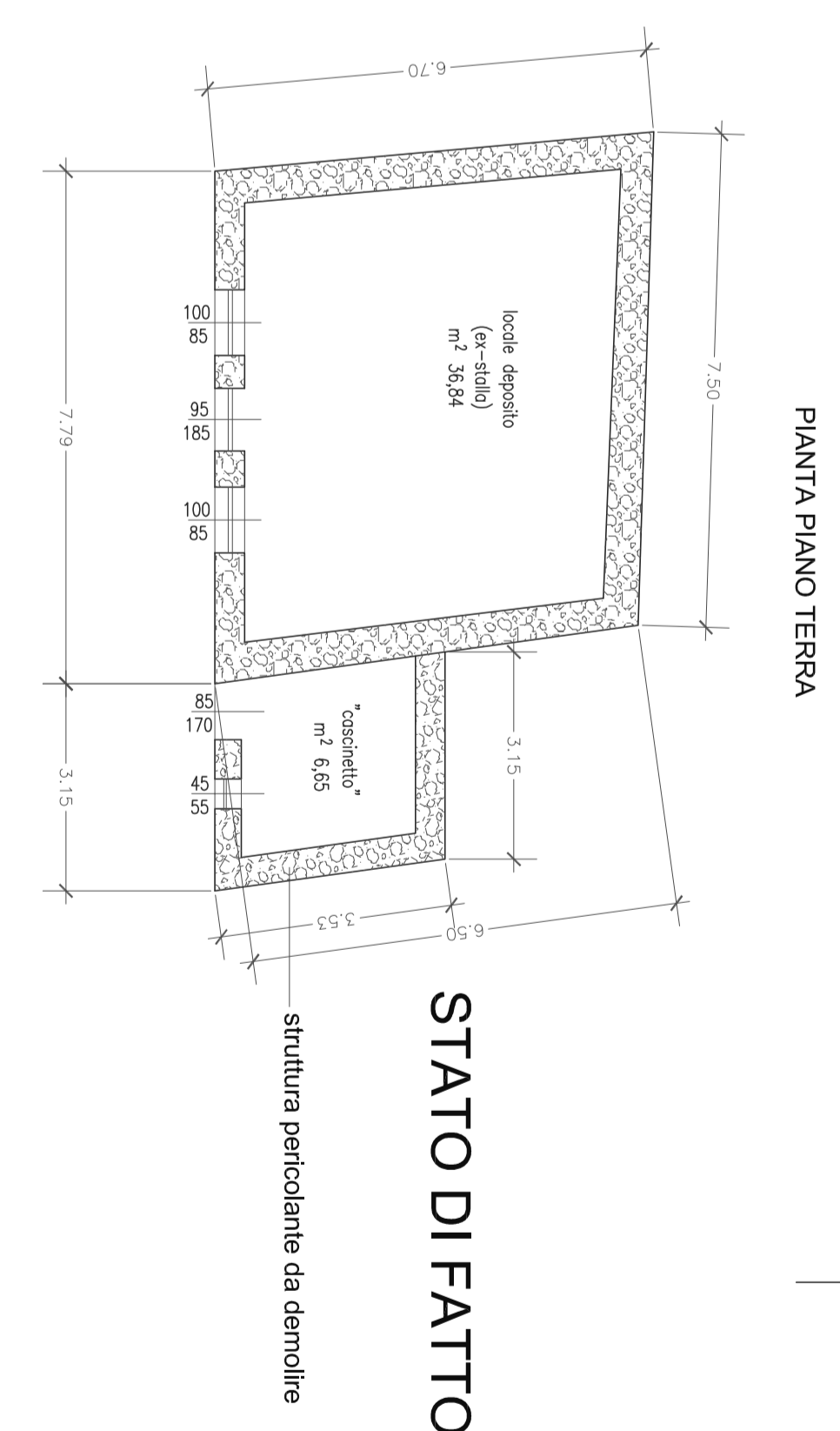

STATO DI FATTO

struttura pericolante da demolire

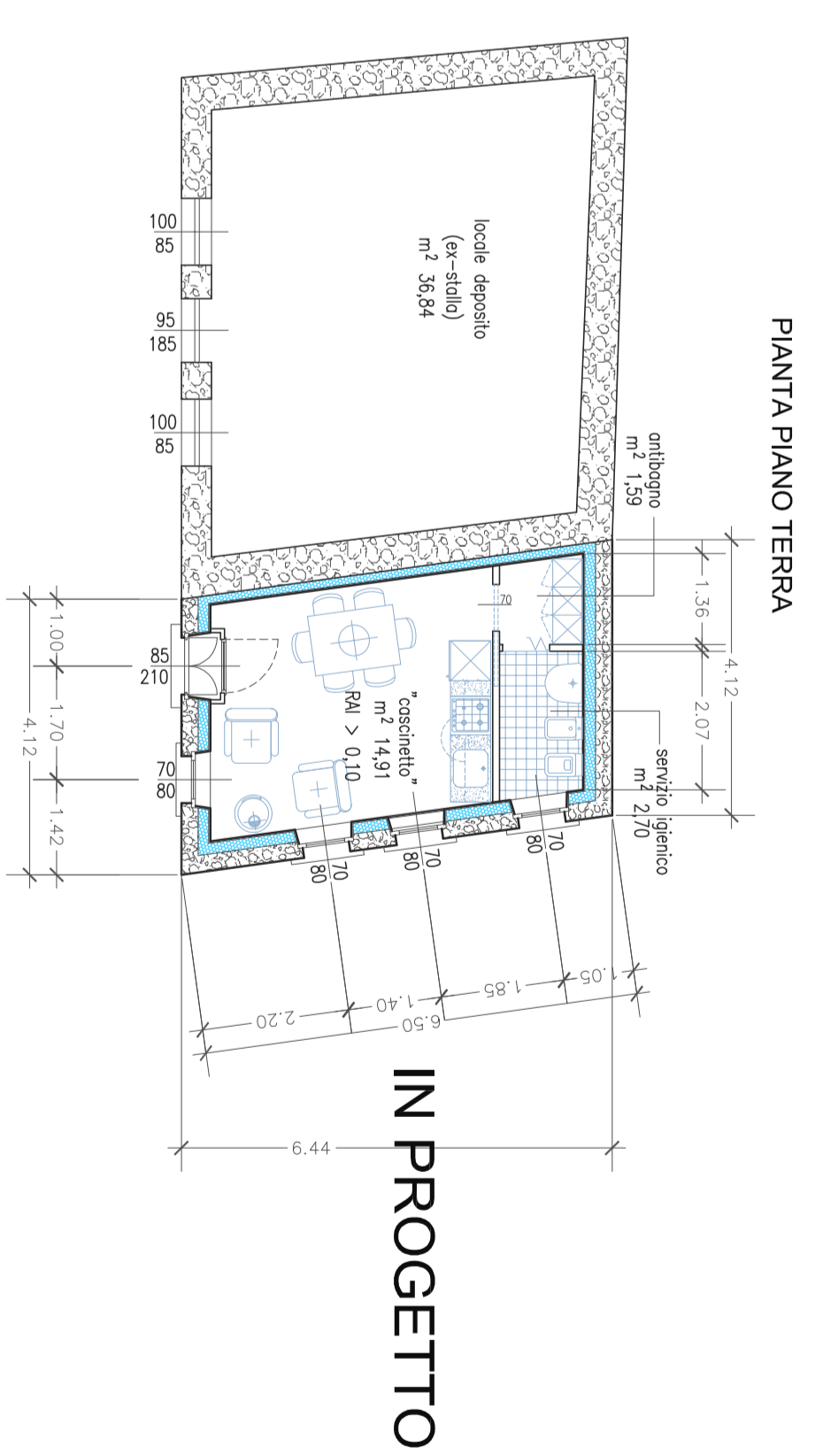
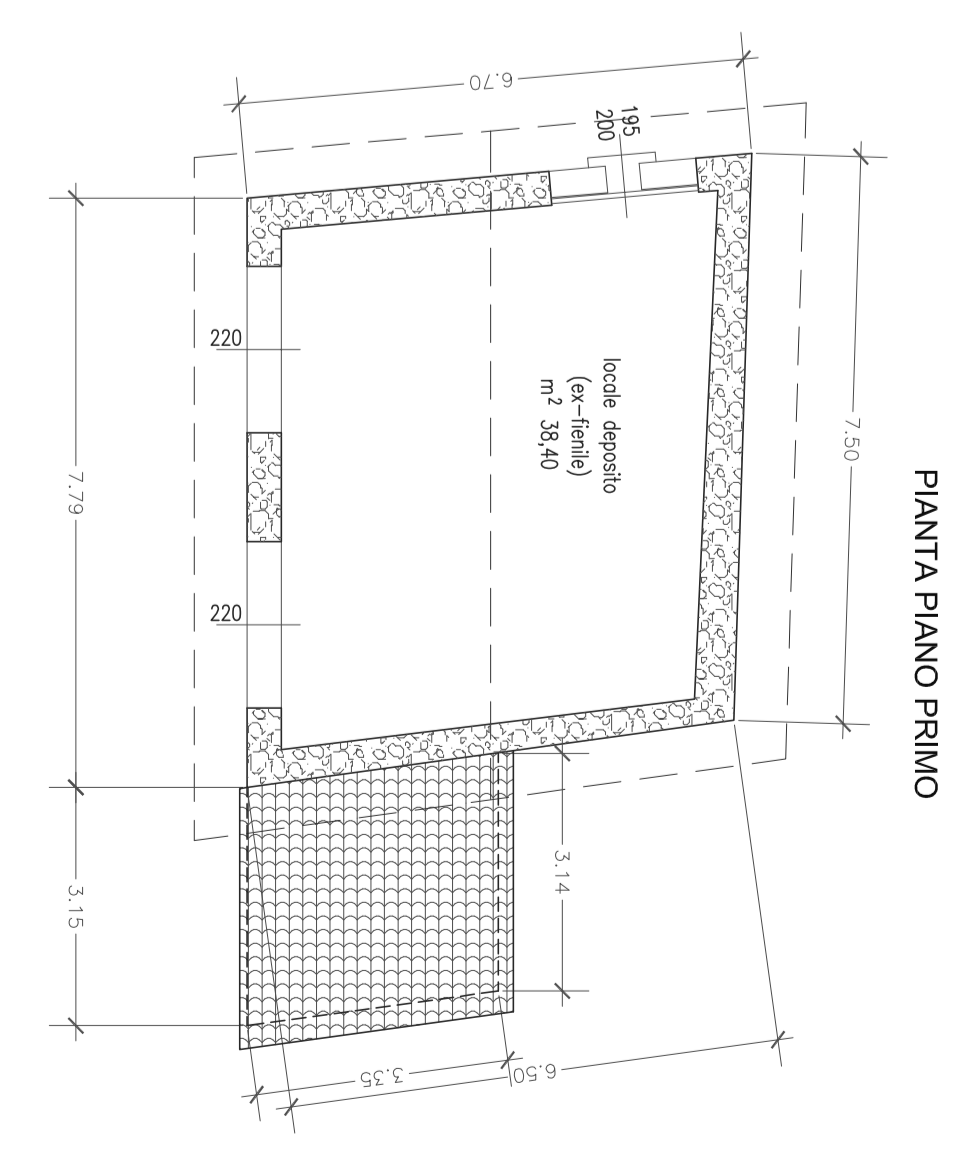

IN PROGETTO

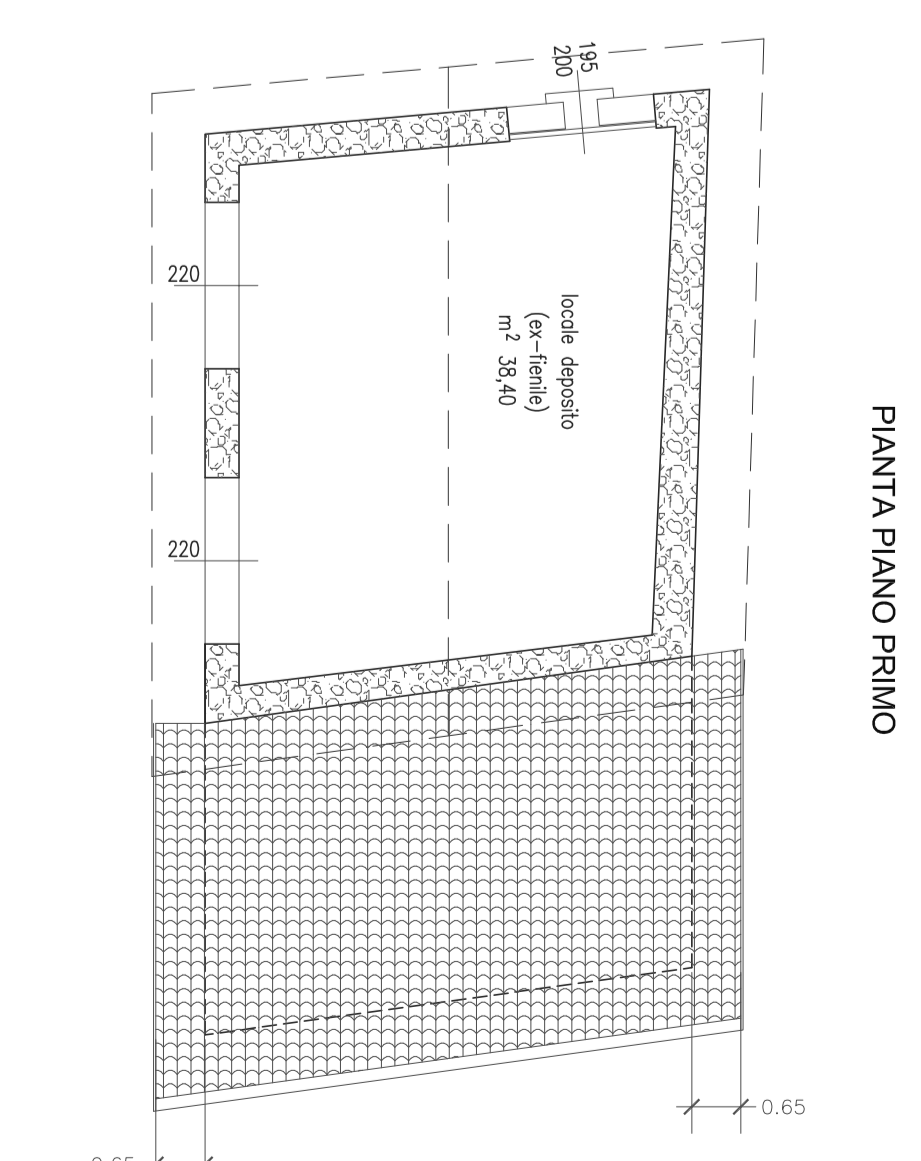

PIANTA PIANO TERRA

PIANTA PIANO PRIMO

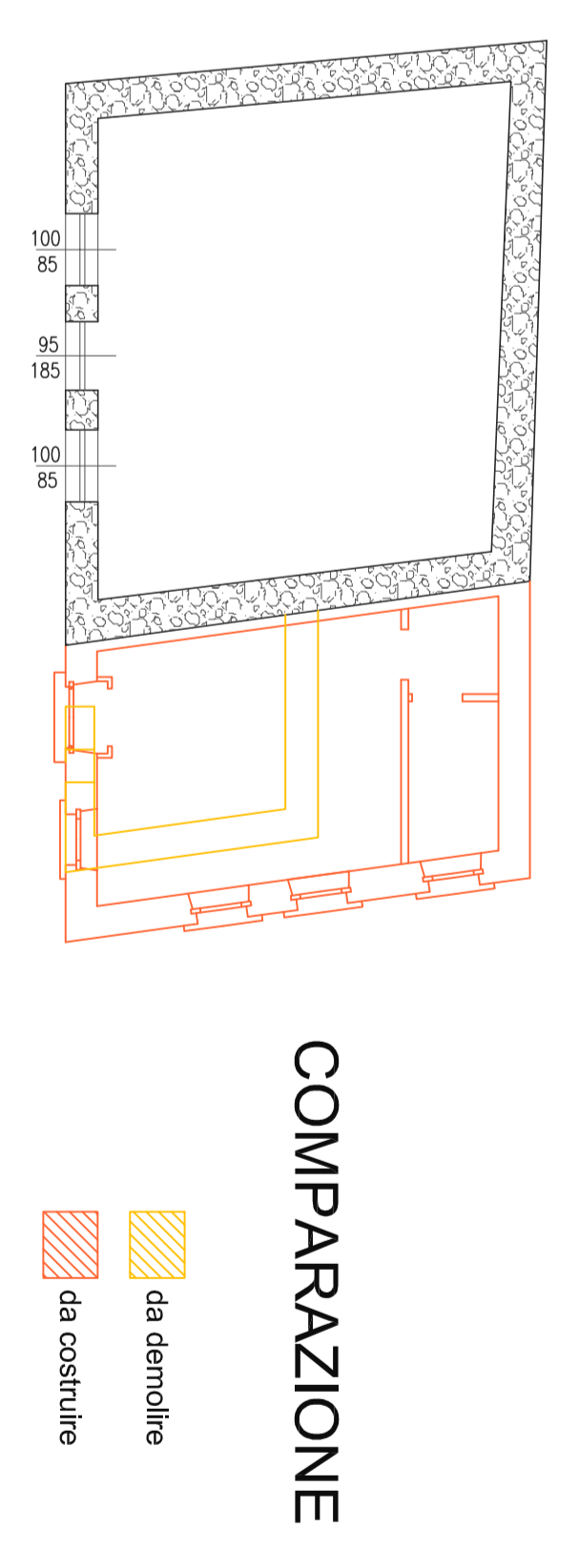

COMPARAZIONE

da demolire
 da costruire

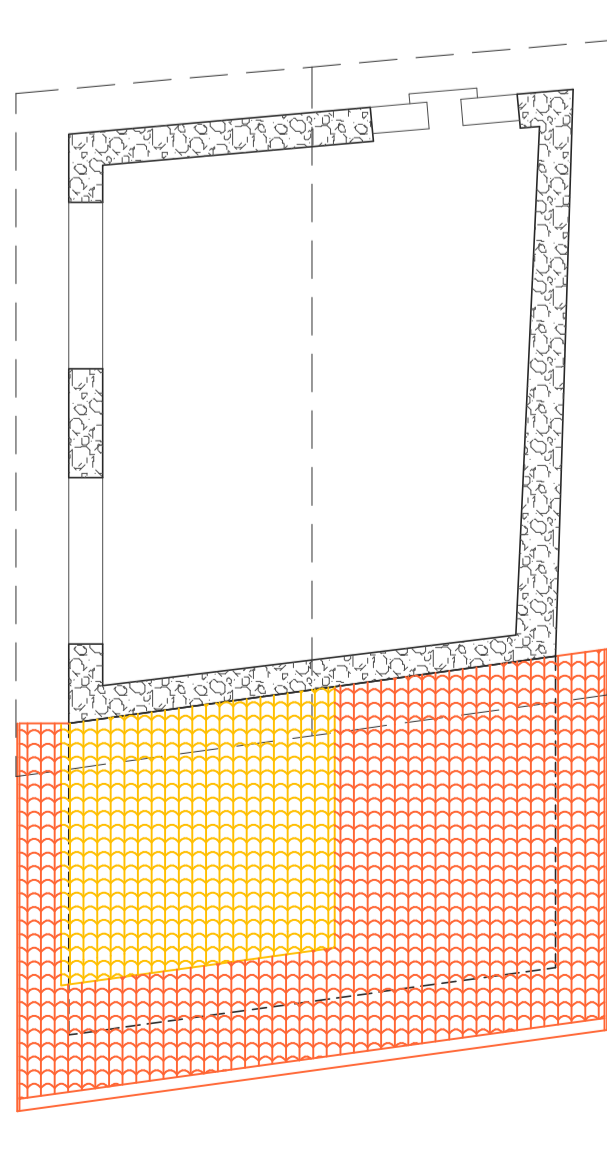

Comune di SERENA (BS)
 progetto di
**PARZIALE RECUPERO DI FABBRICATO EX-URBARE, CON
 DEMOLIZIONE DI "CASCIOTTO" E RICOSTRUZIONI IN
 AMPLIAMENTO DI LOCALE ABITATIVO (CASINALE)**
MAPPALE 4902

STUDIO DI ARCHITETTURA
Bondoli geom. Diego
 Via S. Rocco 10
 24077 SERENA (BS) - tel. 045 245 549

data: 25/07/2018
 foglio: 0
 scala: 0
 rif. to: 0

foglio: **2**
 scala: 0
 rif. to: 0